

ALPHARD



EXPECT THE BEST.
EXPERIENCE BETTER.

Move your world

GO ONE STEP AHEAD.

Experience a vehicle that embodies the philosophy of always going one step ahead, Every detail has been crafted to ensure not just a ride, but an elevated journey where luxury meets precision and performance. Push the boundaries and go beyond expectations.



POINTS FOR YOU



POINT
01

Exterior

A presence that pursues quality in every detail.

Page 04



POINT
02

Interior

A superior cabin designed for elegance and comfort, featuring a solid console for a touch of sophistication.

Page 08



POINT
03

Performance

Dynamic performance that combines power and comfort.

Page 16



POINT
04

Colours

Explore a range of elegant and distinctive colour choices.

Page 18



POINT
05

Specifications

Comprehensive details that define excellence and precision.

Page 19

EXTERIOR



LED rear combination lamp

The large rear combination lamps emit light seamlessly, giving the rear view a sense of elegance. Aero stabilizing fins are set on the outer lens surface to ensure excellent driving stability.



Luxury front grille

The elegance and Luxurious Front Grille design mark your presence wherever you go. (All Type)



A sharp gaze from three eyes.

A large, luxurious combination lamp integrates the functions of LED headlamps (high and low beam), clearance lamps, front turn signals, etc. The irregularly shaped three-eye LED headlamps further ensure nighttime visibility and leave an impression of a powerful gaze.

LUXURY REDEFINED THROUGH EFFORTLESS MOTION





THE ART OF UNDERSTATED LUXURY.



Dual power sliding door
(dual easy closer, anti-pinch function, one-touch seesaw switch)



One-touch seesaw switch



Power tailgate
(with tailgate easy closer, anti-pinch function, stop position memory function, power tailgate switch (vehicle side, tailgate bottom))

INTERIOR

A comfortable cockpit with attention to detail in every aspect.



12.3-inch TFT * Color meter + multi-information display (with meter illumination control)



Head-Up Display



Microcomputer preset driving position system



Steering switch



Digital inner mirror



Electric parking brake/brake hold



Note: Some features are not available in your region



A WELCOMING SPACE THAT PURSUES UNPARALLELED COMFORT.



Executive power seat [second seat]
A seating experience that is one class above the rest.



Executive Lounge
Make your journey a blissful one. Enjoy a unique moment.



Power Long Slide [World's first *]
Comfortable sliding operation.



Rear multi-operation panel (detachable)
A variety of functions can be operated with just a touch of a finger.



Seat operation switch
Intuitive seat operation.
Seat operation switches are located on the inside of the armrest. Intuitive shape allows blind operation.

- [1] Reclining
- [2] Slide/tilt
- [3] Ottoman
- [4] Ventilation
- [5] Heater
- [6] Smart Comfort
- [7] Neutral position

COMFORTABLE SPACE.



Fully automatic air conditioning with independent temperature control for the front, rear, left and right.



Power side sunshades for rear seats (sliding door glass, rear quarter glass)



Rear seat console vent
Spending time in the back seat is now even more comfortable.



Ceiling storage box



14-inch rear seat entertainment system



Hospitality driver's seat switch



Rear heater air curtain
A rear seat space that eliminates the need for a knee blanket. The rear heater outlets are set on the left and right



Comfortable heated seats + ventilation seats (front and second row)
Attention to detail creates a relaxing time.





THE OVERWHELMINGLY SPACIOUS INTERIOR ALLOWS YOU TO SPEND YOUR TIME HOWEVER YOU LIKE.



Reading light

A reading light that allows you to read documents comfortably even at night.

A reading light that uses high-brightness LEDs that allow you to comfortably read documents even in a dimly lit car.



Rear seat LED dome lamp

Lighting that can illuminate the entire rear seat or each seat individually.

A single interior light can be used to illuminate the entire room in living mode or each seat in personal mode.



LED roof color illumination (with color change and dimming function)

A total of 64 colored linear lights create a colorful interior illumination.

The colored LED linear lights on the ceiling are available in a wide variety of colors, with 14 basic colors and 50 custom colors for a total of 64 colors.



Hospitality central Panel *

A centralized hospitality switch that can be used to operate the LED roof color illumination, rear seat LED dome lamps, rear seat power side sunshades *, sliding door power windows, power door, and independent left and right moonroofs *.



Super long overhead console [Toyota first *1]

A smart ceiling that combines functionality and storage space.

Lighting, various switches, air conditioning vents, and other functions that were previously scattered throughout the ceiling have now been consolidated in the center of the vehicle. The ceiling is neat and tidy, and easy to use from anywhere in the rear seats.

[Lighting]

- [1] Reading light *2
- [2] Rear seat LED dome lamp
- [3] LED roof color illumination

[Air conditioning]

- [4] Ceiling air conditioning vent
- [5] Rear air conditioning control panel

[Operation]

- [6] Hospitality central switch *3

[Utility]

- [7] Ceiling storage box
- [8] Rear seat display storage *2

PERFORMANCE

From sheer comfort to precise control, the Alphard excels at delivering seamless performance for the most enjoyable rides.



Automatic - CVT



TNGA * platform/high-rigidity body



2.5L 2AR-FE engine and hybrid 2.5L A25A-FXS engine



Suspension

It absorbs vibrations smoothly to create a unique and comfortable ride for you



2.5L hybrid system

Achieving both excellent driving performance and low fuel consumption.



EV drive mode * / Eco drive mode

You can switch according to the situation.



COLOURS

EXTERIOR



PLATINUM WHITE PEARL MC (089)



PRECIOUS LEO-BLOND (4YZ)



BLACK (202)



PRECIOUS METAL (1L5)

INTERIOR



BLACK (20)



NEUTRAL BEIGE (41)

Note: Some features are not available in your region

SPECIFICATIONS

		Hybrid	Gasoline	
		AAHH40R-PFXLB	AGH40R-PFXLK	
Dimensions & Vehicle Weights				
Overall	Length x Width x Height	(mm)	5010 x 1850 x 1950	
	Wheelbase	(mm)	3,000	
	Ground Clearance	(mm)	161	
	Gross Vehicle Weight	(kg)	2,830	2,650
Fuel Tank Capacity	Total	(L)	60	75
Engine				
Engine	Model Code		A25A-FXS	2AR-FE
	No. of Cyls. & Arrangement		4-Cyls. IN LINE	
	Displacement	(cm3)	2487	2494
	Fuel System		SFI	
	Fuel Type		PETROL-HYBRID	PETROL
Max. Output		(kW / RPM)	140 / 6000	134 / 6000
Max. Torque		(Nm / RPM)	239 / (4300-4500)	235 / 4100
Performance				
Min. Turning Radius	Tire	(m)	5.8	
Min. Turning Radius	Body	(m)	5.9	
Drive Train				
Transmission	Type		CVT	
Brake System				
Brake Type	Front		Ventilated Disc brake	
	Rear		Ventilated Disc brake	
Suspensions				
Suspension Type	Front		MacPherson strut	
	Rear		Double Wishbone	
Other Specifications				
Tire And Disc Wheel			225/55R19	
Seating Capacity			7	
Auto And Easy Closer Door			With	
Wireless/smart Door Lock			With Smart	
Headlamp			Led	
Rear Seat Entertainment			With (14 Inch)	
Audio			Display Audio	
Panaromic Moon Roof			With	
Srs Air Bag			With	
VSC			With + Brake Hold	
ABS			With	
Hill Starting Assist System			With	
Front Seat Belt			With	
Rear Seat Belt			With	
Rear Air Conditioner			With	
Rear Row, 1 Seat - Power + Reclining + Captain + Ottomun + Tilt Cushion + Massage			With	

The streamlined lines of the body create harmony and sensibility

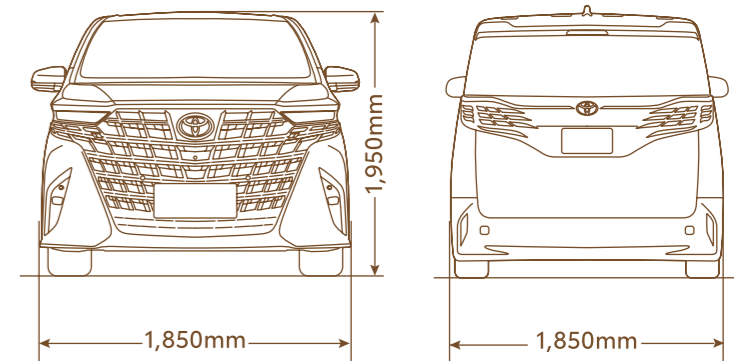
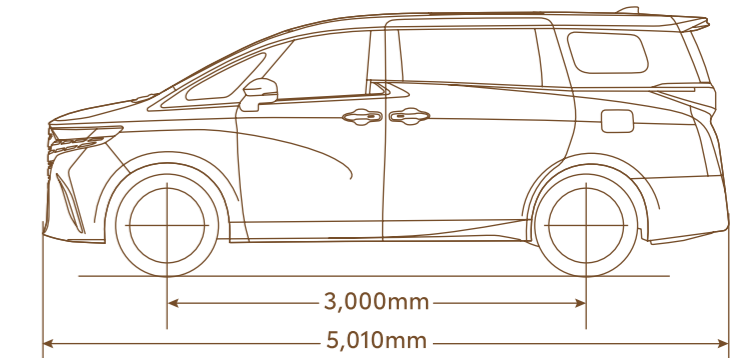

Diagrams shown are for illustration purposes only

- Additions of extra features may change figures in this chart.
 - Vehicles pictured and specifications detailed in this catalogue may vary from models and equipment available in your area.
 - Vehicle body colour might differ slightly from the printed photos in this catalogue.

- Toyota Motor Corporation reserves the right to alter any details of specifications and equipment without notice. Details of specifications and equipment are also subject to change to suit local conditions and requirements. Please inquire at your local dealer for details of any such changes that might be required for your area.



 **TOYOTA LANKA**

Toyota Plaza, 337 Negombo Rd, Wattala.
Tel: 0112 939 000
E-mail: sales_inquiries@toyota.lk Web: www.toyota.lk

